



Ethernet

To the Field



Ethernet-APL™—enabling the future of process automation.
Ease of adoption. Seamless integration. Simplified installation.
Greater range. Valuable data.



Ethernet-APL

at AICHEMA Pulse

The AICHEMA Pulse live virtual event on June 15 and 16, 2021, aims to bring people, ideas and technologies together to explore new opportunities for collaboration.

Ethernet-APL will be represented at the show with an independent virtual booth and will hold a variety of business and technical live talks on the Ethernet-APL technology.



Meet us at
Achema Pulse

Live Program

June 15, 2021

14:00

Ethernet-APL: Press conference

14:30

Ethernet-APL: Introduction to Ethernet-APL

15:30

Ethernet-APL: Customer panel

16:00

Ethernet-APL: Multivendor demonstration

16:30

Ethernet-APL: Engineering guideline and end user preparation

June 16, 2021

14:30

Ethernet-APL: End to end device to controller use case

15:00

Ethernet-APL: Existing installation implementation: brownfield and/or greenfield

15:30

Ethernet-APL Infrastructure: Switches and installation for enhanced plant capabilities and explosive atmospheres

16:00

Ethernet-APL: Port profile overview and acceptance testing

16:45

Ethernet-APL: PHY readiness and technical overview

Learn more at www.ethernet-apl.org



Welcome from the Chair of the APL Project—Dr. Jörg Hähnliche

The process industry is facing a radical change in terms of digitization. Many developments have been initiated to obtain more information from the process in order to be able to produce more efficiently or more flexibly or bring more flexibility into the internal processes (Maintenance). Ethernet-Advanced Physical Layer (Ethernet-APL™) is the key technology here that connects the field level of process automation systems to the Industrial Internet of Things, making it the decisive step in achieving a higher degree of digitization a reality. Ethernet-APL not only brings Ethernet technology to the process field device, but also provides a secure, future-proof solution for the requirements of process users.

The fact that the well-known organizations for communication systems for the automation of process engineering automation systems FieldComm Group, ODVA, OPC Foundation and PI as well as twelve industry partners have joined forces to provide a uniform solution means that the most important prerequisite for rapid worldwide dissemination through the one standard has been met. The first practical tests of Ethernet-APL are already underway on the basis of prototypes at the companies involved in the project and at users—e.g. BASF—and have been successfully completed.

The specification work is now largely complete and the first switches and field devices with Ethernet-APL are expected in summer 2021. The specified roadmaps were adhered to so that the chip manufacturers were able to provide their solutions. The Conformance Specification, which is important for interoperability, will also be released this year.

At the same time, the other supplementary work, which is particularly necessary for user acceptance and safe, long-lasting industrial use, will also start. These include the completion of the Engineering Guideline, the implementation of test cases and tools, and the establishment of certification processes. Real use cases are also an important building block in this context, so that the technology is developed in a practical manner. This is where the final adjustments are made and subtleties are incorporated from the user's point of view.

After all important work regarding certification, standardization, etc. will be completed this year, the first concrete projects with Ethernet-APL will start next year. Among other things, the test facilities will be equipped with new devices and no longer just prototypes. From our experience, it is important that the implementation of the use cases is started quickly. This is the only way for users to gain confidence in the new technology.

All this work is taking place in close cooperation between the organizations and industry partners involved. Therefore, all players are confident that a wide range of Ethernet-APL devices will be available from 2022 and will be shown at the postponed Achema in April 2022.



J. Hähnliche

Dr. Jörg Hähnliche
APL Project Steering
Committee Chairman

Why Ethernet-APL will enable the future of process automation

To understand the meaning of Ethernet-APL for the field of process automation, we have to take a closer look at the present. In the manufacturing industries, the Industrial Internet of Things (IIoT) and Industries 4.0 are already part of everyday operations. Digitization and new technologies are poised to bring these widely into process automation as well.

As digitalization becomes more prevalent, it is becoming increasingly important to gain access to data from every part of a plant to extract more value for companies. However, in the process industry, there are special requirements, such as enabling seamless and fast communication from the field level to the information level, including in explosive hazardous areas and under harsh conditions that has made it difficult to migrate to more digital solutions. In this sensitive industrial sector, any deployment of new technology must be thoroughly tested and provide added business benefits. Furthermore, new technology cannot require extensive training for installing and maintenance. Meeting the needs of process automation is not an easy task. This is why it has been a challenge to digitize the field level in the process industry so far—until now.

Today's common physical layers are too slow

But first of all, let's have a look at the current situation—For many decades, process automation instruments have been connected to control systems through a simple 2-wire cable that also supplied power to the instruments. The physical characteristics of the wire itself and the electrical characteristics of the signals that pass along it are together called the physical layer. The two most common physical layers found in process automation are 4-20mA and fieldbus. They both have the disadvantage that they are slow, falling far short of today's fully digital physical layers.

The last meter of Ethernet connectivity

This is why leading suppliers to process automation recognize the need from their customers to enable Ethernet to the field. Ethernet is the de-facto communication standard in enterprises, but until now it did not meet the requirements in the field of process automation without modification.

A key group of leading automation suppliers and standards development organizations have come together to accelerate development and adopt a new open standard for an Ethernet physical layer for the use in process automation and instrumentation that can:

- » be deployed in hazardous areas
- » allow long-reach connectivity
- » include an option for device power over the line

This new Ethernet advanced physical layer, called "Ethernet-APL," together with the automation protocols that define the structure and meaning of information being transmitted to and from field devices, will be one of the key enabling factors to bring Ethernet enabled instrumentation and infrastructure to the field level of process automation. This last meter of Ethernet connectivity would allow any enterprise boardroom to obtain data quickly and efficiently from all regions of its extensive network.

Advantages of Ethernet-APL

Why should you be interested in Ethernet-APL? Simply said: it is the future of process automation. Ethernet-APL has many advantages:

- » simplicity in engineering and maintenance
- » accelerates deployment
- » redundancy mechanisms for high availability
- » increases asset optimization
- » open technology to avoid vendor lock-in
- » supports powerful integration technologies
- » reduces risks
- » robust connection technology with an explosion protection option (intrinsic safety)

Ethernet-APL should be seen as a future investment, because it enables you to reduce the total cost of ownership.

A future-proofed technology

Ethernet-APL is a full Ethernet standard. It supports all current and future higher-level communication protocols and services and flattens the network infrastructure. Ethernet-APL removes the need for protocol conversions and gateways, providing barrier-free and parallel accessibility and providing the extra speed required in a data-driven economy.

This technology combines the best attributes of Ethernet communication with two-wire installation techniques. This makes Ethernet-APL easy to deploy as a standard for field applications, from process plants with hazardous areas up to Zone 0/Division 1 to hybrid plants, employing technologies from discrete and process automation.

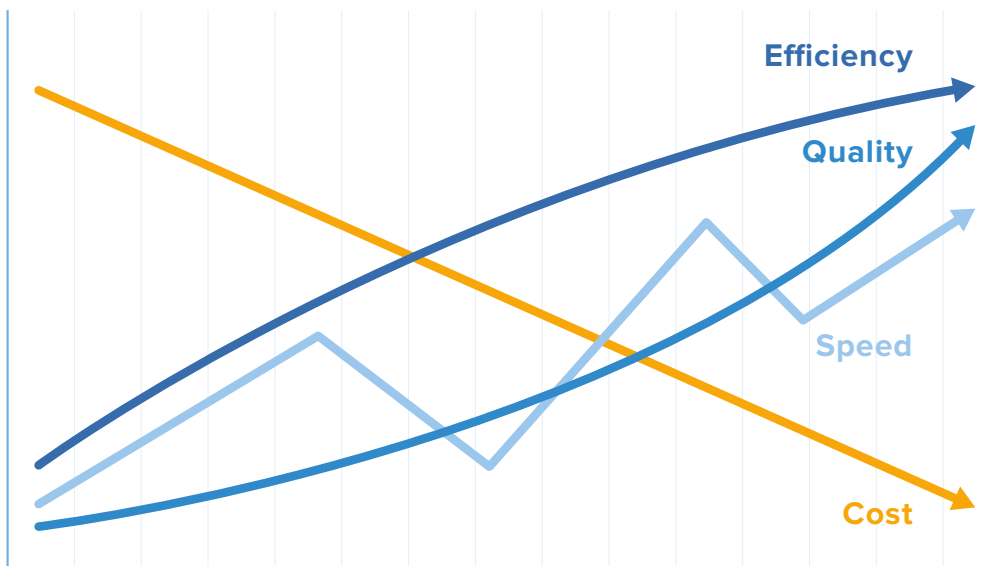

Figure 1

Ethernet-APL in the Field of Process Automation— the easy way!

Ethernet-APL is ready to be used as the next standard for field applications, including installations in hazardous areas. It has been developed based on the requirements from end user organizations like NAMUR. Besides key features like 10 Mbit/sec. communication bandwidth, two-wire cabling with power for field devices, one of the major advantages is “easy to use”. Let’s have a look at what makes Ethernet-APL the most optimal solution:

Comparison of Technologies for the Field of Process Plants	4-20 mA with HART	Fieldbus	Ethernet 100BASE-TX	Ethernet 10BASE-T1L
Single Pair Cable	✓	✓	✗	✓
Communication	1.2 kbit/s half duplex	31.25 kbit/s half duplex	100 Mbit/s full duplex	10 Mbit/s full duplex
Reference Cable	n/a	Type ‘A’	CAT 5/6	Type ‘A’
Trunk Length	n/a	1900 m (typ. 700 m)	100 m	1000 m
Spur Length	n/a	120 m	n/a	200 m
Screw Type Connector	✓	✓	(✓) ¹	✓
Polarity independence	✗	(✓) ³	n/a	✓
Intrinsic safety option	✓	✓	(✓) ²	✓
One network technology from field to enterprise	✗	✗	✓	✓

Figure 2

- 1: Available up to 1 GHz, certified for Zone 1
- 2: Available by 100BASE-TX-IS from Intrinsically Safe Ethernet Working Group
- 3: Dependent upon vendor

Installation made easy with Ethernet-APL

New technologies often require new installations, special know-how and effort to dismantle the existing technology. All these points lead to high additional costs, which make the investment highly complex and risky. Ethernet-APL has been developed with a different approach: it should easily fit in the existing process automation topology—without additional costs, such as for staff training or installation of new cables and connectors.

1. Standard connectors can be used

Ethernet-APL does not require any special connectors or connection technologies that may need dedicated tools for assembly; it uses standard and Proven In Use screws or spring clamp connectors, as well as common M8 or M12, and even RJ45 is possible for non-powered connections. That also means that companies do not have to train their operational staff to use new tools and processes.

2. Existing fieldbus installations can be re-used

Cables from existing fieldbus installations with Foundation Fieldbus H1 and PROFIBUS PA can be reused and among others, Ethernet-APL also supports the IEC61158-2 type A specification. Companies can save a lot of time and money using the existing installations but simultaneously take advantage of a new technology.

3. Fits into hazardous areas and large installations as well as compact ones

The network installation can be based on the trunk-spur topology which is well known from fieldbus installations. The power switch typically installed in the

control room converts a 4-wire Ethernet network into the 2-wire Ethernet-APL trunk and supplies up to 92 W to the network. Multi-spur field switches get power over the trunk, connecting and supplying the field devices.

With a maximum of 1000 m trunk length and up to 200 m spur length, the topology shown in figure 3 is ideal for large installations and long distances. For installations in hazardous areas, such field switches are certified for installation in Zone 1 or DIV 2 and with spurs supporting explosion protection techniques like “intrinsic safety” for field devices even in Zone 0 or DIV 1.

Installations in a more compact layout may also use the pure star topology (figure 3) which is well known from Ethernet. Here the field switches themselves are connected to a 4-wire Ethernet network, while the field devices are also connected to the spurs including their power supply. This allows an even simpler integration into existing Ethernet backbones but requires a separate power supply for each field switch. Explosion protection like intrinsic safety for field devices is available as well.

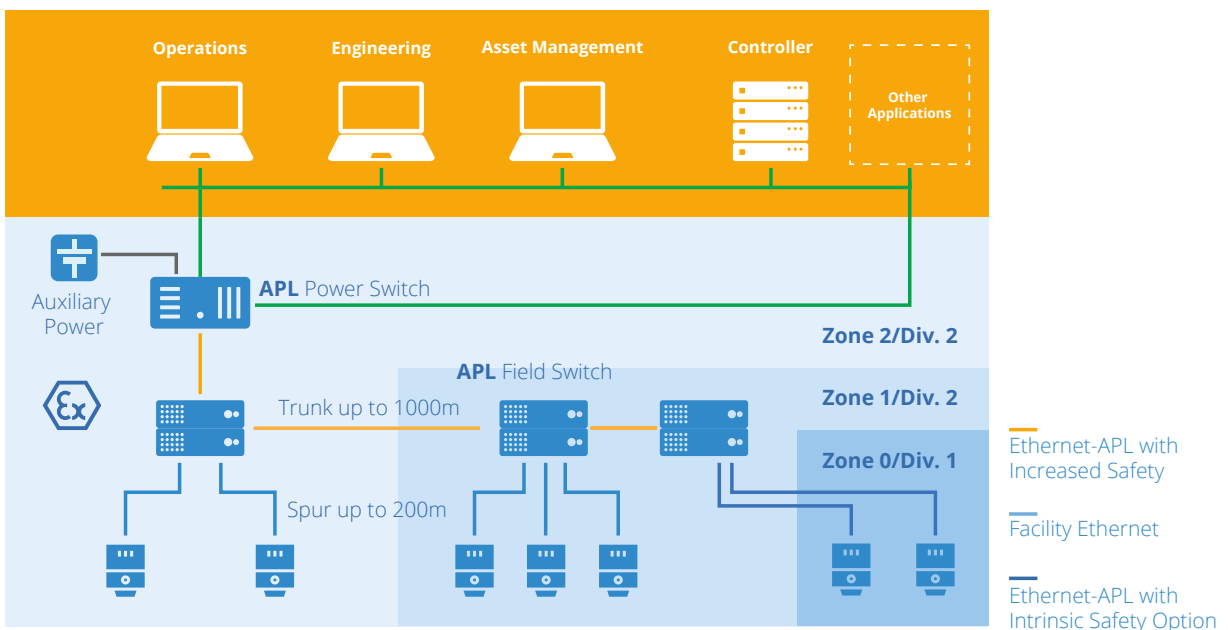

Figure 3

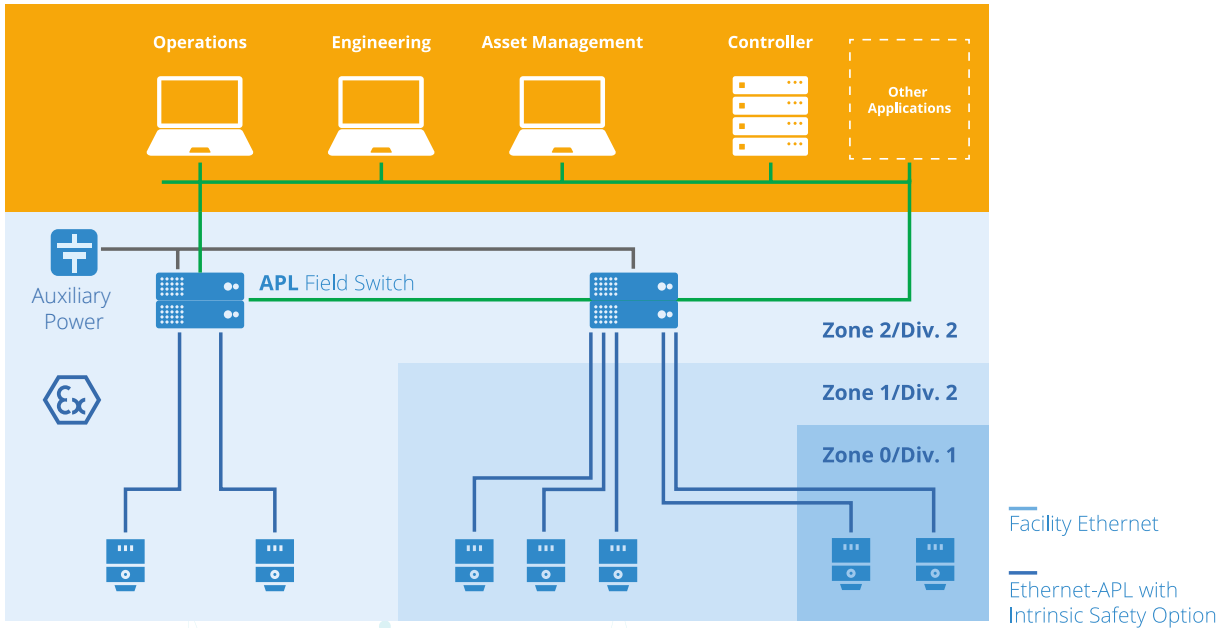

Figure 4

Facilitated explosion protection

Ethernet-APL supports various explosion protection techniques and can be used with different field devices in hazardous areas. However, intrinsic safety is one of the most favorable types of protection when it comes to process automation. Intrinsically safe devices are easy to handle—installation, modifications or maintenance can be completed easily.

The new 2-WISE explosion protection (2-Wire Intrinsically Safe Ethernet) for Ethernet-APL enables the use of field devices up to Zone 0 as well as DIV 1. Using standardized Ex i safety parameters, Ethernet-APL devices from different manufacturers can be interconnected within the framework of the specified boundary conditions of Ethernet-APL or 2-WISE without calculatory verification of intrinsic safety and without taking cable parameters into account.

Ethernet-APL is based on the well-known and proven in use industrial Ethernet technologies which allow the utilization of standard Ethernet components, tools and expert knowledge and combine this with comfortable new solutions dedicated to the process automation requirements. This is why Ethernet-APL is better than any other solution from the past and will become the standard for digital network installations in process plants very soon.



Ethernet-APL is a variation of 2-wire Ethernet that has been optimized for the process industries. Compare the features of standard SPE versus Ethernet-APL:

	SPE	Ethernet-APL
IEEE standards supported	1000BASE-T1, 100BASE-T1, 10BASE-T1S, 10BASE-T1L	10BASE-T1L
Auto-negotiation	✓	✓
Energy Efficient Ethernet EEE	✓	✗
Power over Data Lines PoDL*	Power Sourcing, Powered Device	✗ (own supply concept)
Power for Devices	6 ... 60 V, 100 ... 1360 mA, max. 60 W	Trunk: typ. 48 V, 92 W Spur: typ. 10 V, 0.54 W
Cables	IEC 61156	+ IEC 61158-2 (fieldbus type A)
Connectors	IEC 63171	RJ45, M8, M12, terminals
Explosion protection concept	✗	2-WISE, Ex i, Ex e (for installation)

Figure 5

* PoDL not compatible to PoE, not compatible to Ethernet-APL



Conformance testing for Ethernet-APL products: ensuring interoperability

In addition to providing the specifications for Ethernet-APL, the APL Project has also developed conformance testing plans for Ethernet-APL devices. However, Ethernet has existed for many years and has been integrated into many products. Why is special testing needed?

Conformance testing has traditionally been a key way for end users to gain assurance that the products they are sourcing from different vendors will interoperate. However, as we think of it in our offices or in the industrial space today, Ethernet is a four wire Ethernet with separate power, and conformance testing services by network organizations has typically focused on the protocols. With Ethernet-APL both data and power are being introduced over only two wires. Therefore, a way to measure conformance to the specifications needs to be provided for end users to have the same assurance of interoperability. In addition, there are also special requirements in process automation that are not found in other industries which must be considered.

Special requirements for hazardous areas

Perhaps the most common special requirement involves deployment in unsafe areas. Process automation has very specific demands that must be met to assure the safe installation of products when they involve power and are used in hazardous areas. It is typically accomplished with the two-wire power and data type standard with a technique called intrinsic safety (IS). Intrinsic safety is an IEC specification and not handled within IEEE. This means that the Ethernet physical layer of an Ethernet product is governed by the IEEE—but the intrinsic safety and the discrete power requirements for the industrial space are driven by the IEC. Therefore, there is an additional set of requirements above what is defined by the IEEE and generally acceptable for consumer and light industrial applications that must be examined.

In addition, the APL Project has developed specifications for port profiles for Ethernet-APL in order to define the power and signaling requirements. These port profile specifications, which are integrated into the network specifications for the key industrial networks, also outline expectations for immunity to noise in support of different links and cables that would be necessary for the industrial space. The end result is that there are IEEE requirements and Ethernet-APL specific requirements. This means that a product that is conformant to IEEE may not meet all the requirements of Ethernet-APL. However, an Ethernet-APL product must meet all requirements for IEEE usage as well as those for APL.

Furthermore, the Ethernet-APL port profile specifications allow for discrete power classes including those for intrinsic safety as well as for non-intrinsically safe applications. Suppliers can create higher power instru-

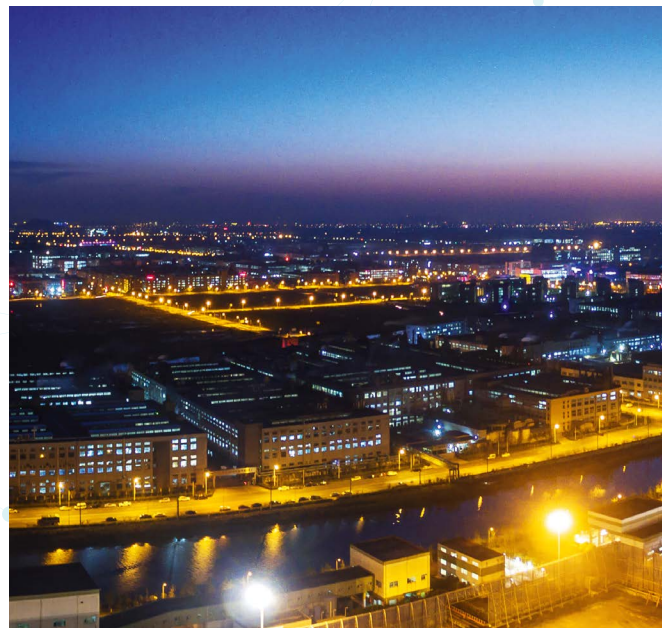

ments that in turn can only be used with specific high power ports on an Ethernet-APL switch or suppliers can allow for an additional power supply in their device.

Testing program: IEEE and Ethernet-APL specific operations

FieldComm Group, Profibus/Profinet International, ODVA, and the OPC Foundation will implement a testing program around the physical layer which will confirm both:

- » the IEEE operations of the product
- » the Ethernet-APL specific operations of the product, including power and signal as well as noise immunity and other requirements

These items are all addressed within the conformance test specifications.

Common set of tests will be accepted by all organizations

Furthermore, if a company tests an Ethernet-APL pressure transmitter for Profinet, for example, and then creates a version for HART-IP on the same physical layer, then the company would only need to have the HART-IP functionality tested. The Ethernet-APL physical layer will face a common set of tests at each organization and those test results will be recognized by each of them.



Ethernet-APL— the missing link to enable digitization in the field



In this interview, Dr. Kai Krüning from BASF tells us how Ethernet-APL can help drive digitization and seamless communication within the field of process automation. Furthermore, he points out why Ethernet-APL is the missing link to enable digitization in the field in the process industry.

As the “missing link to enable digitization in the field”, which technical specifications and advantages of Ethernet-APL would you highlight for potential users?

Having a look at Ethernet-APL from a user’s perspective there are many advantages, but for me three of them are the most critical. Starting with the cabling: Type A cables are needed for Ethernet-APL. That’s the same cable type we are currently using for our fieldbus installations—giving us the chance to easily migrate existing fieldbus installations. Furthermore, it allows mixed installations of fieldbus and Ethernet-APL. The second advantage I would like to highlight is the so-called 2-WISE standard. 2-WISE stands for “2-Wire Intrinsically Safe Ethernet”. This allows all users an easy installation of Ethernet-APL in hazardous areas. Data can be transmitted over long distances with faster speed (10 MBit/s).

On top of that, Ethernet-APL is a full Ethernet standard and not just created for the process industry. It fits into all other Ethernet standards—also within the ones, which will be created in the future. That’s why Ethernet-APL is a future-proofed technology with a long lifecycle.

Dr. Krüning, you just mentioned the faster speed of Ethernet-APL. Do we really need 10 MBit/s for field devices in process automation?

I often get this question, but I think we should shift our focus from the pure numbers (10 MBit/s) to the advantages of a higher bandwidth. So far, current fieldbus installations do not provide enough bandwidth to make use of different data sources in real-time.

Let’s explain this with an example: In predictive maintenance it is important to monitor and evaluate relevant information of field devices over their entire lifecycle, e.g. static information as configuration parameters, engineering information or device identification and dynamic information such as health diagnostics and additional measurements.



This information has to be correlated and reconciled with other data sources, e.g.

- » process data from the DCS
- » engineering data from planning tools
- » maintenance data
- » PIMS and alarm monitoring
- » data from the ERP System

To realize predictive maintenance, we need to use these different data sources plus historical data from field devices. This gives us the possibility to train a human expert or an AI system to predict the future system behavior. Having this example in mind, you can imagine that we need more bandwidth to simultaneously communicate with every single application on the field. Ethernet-APL provides enough bandwidth for that purpose.

So far, we are talking about Operational Technology. But to really take advantage of digitization, we need to integrate the fast-changing IT world into the very stable OT world. Does Ethernet-APL help to solve this challenge?

Ethernet-APL can be the enabler for IT/OT convergence. With Ethernet-APL we don't have to build a connection out of every single field device onto the DCS and then to our plant specific cloud. We are bypassing our DCS, having the advantage that we do not have to bother our control system with things it does not need for its operation. Using Ethernet-APL, all we need to do is to implement the OPC-UA Gateway, which translates the user specific protocol (the Ethernet protocol running on Ethernet-APL) to OPC-UA. Our data can then be read by the IT easily.

Ethernet-APL enables seamless communication and real-time data transfers with central data consolidation and analysis. The advantages are obvious: Ethernet-APL is bringing digitization towards the field level of process automation and is releasing the potential of the field. I'm looking forward to the next steps of launching Ethernet-APL and to a digitized future within the field of process automation.

FieldComm Group

FieldComm Group believes that digital transformation in the process automation industry is a revolutionary concept implemented in an evolutionary way.

Bridging the OT and IT worlds requires consideration of the installed base of field instruments ... of which over 70 million support HART. Introduction of 2-wire intrinsically safe Ethernet-APL technology, initially to network components, immediately simplifies access to these instruments driving value for the end user. We heartily congratulate the Ethernet to the Field Project for all the work completed to achieve this milestone.

Additionally, enhancements to the HART-IP standard coupled with Ethernet-APL will enable HART-IP to extend from today's infrastructure products all the way to the field device ... with minimal change in host system software. PA-DIM, the Process Automation Device Information Model, supports the Namur Open Architecture (NOA) thus providing the device information to seamlessly enable enterprise IT analytics systems independent of automation protocol while also future-proofing user investments.

As a founding standards development organization of the Ethernet to the Field Project, FieldComm Group has led the conformance activities of the team with one principal goal in mind ... assuring that users who begin to transition to Ethernet-APL infrastructure and devices achieve the same level of multi-vendor interoperability that they have come to expect from current process automation technologies.

With over 30 years of experience developing standards, test processes, and product registration services we are confident that equipment supporting Ethernet-APL will conform to the rigorous and often hazardous requirements of process automation.



Ted Masters

FieldComm Group
President and CEO

ODVA

ODVA is actively engaged in the industry-wide effort to promote adoption of long reach and hazardous area capable Ethernet-APL, which will soon open up the process industry to the high speed and rich data afforded via Ethernet.

ODVA is committed to working together with leading standards organizations and industry partners to develop the technology, guidelines, and best practices to assure successful deployment of Ethernet-APL to the field. Ethernet communication will be a key factor in moving critical information from the device to the cloud for future applications with modern IIoT and Industry 4.0 solutions. EtherNet/IP will be one of the key available Ethernet communication networks as it was originally designed for the future with a basis in IP technology and has been named as one of the minimum binding requirements for field level to higher system level communication by NAMUR.

EtherNet/IP supports NAMUR NE 107 Process Diagnostics, includes a translation mechanism for the integration of HART devices, and works efficiently and seamlessly with FDI technology. Furthermore, EtherNet/IP enables leading application level cyber security and safety solutions via CIP Security and CIP Safety. The Ethernet-APL physical layer will make usage of Ethernet in the field of process commonplace as a result of the determined and cooperative efforts of key industry players.

Interest from end users has been enthusiastic and will help drive adoption of Ethernet-APL, which will enable companies to gain the benefits of valuable additional data insights and drive cost savings. As a result, networks like EtherNet/IP will be able to be used across the process plant to connect devices to higher level infrastructure as an enabler to better performance for IIoT, Industry 4.0, NOA, and OPAF.

We congratulate the APL Project for completion of this important milestone for the process industries!

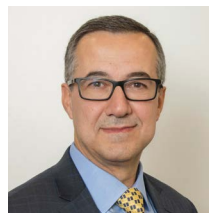

Al Beydoun

ODVA
President and Executive Director

OPC Foundation

OPC UA and Ethernet-APL: A common-sense Partnership between two enabling technologies

The OPC Foundation congratulates the Ethernet-APL Project on the announcement of their achievement of a critically important milestone of cross-vendor utilization of their standard. We have joined this initiative because we strongly believe that the combination of OPC UA over APL will be a key technology for decades to come.

The key to APL technology is its ability to extend capabilities and simplify applications for end users by scaling an Ethernet-based IT infrastructure from edge to sensor: APL is a perfect enabler for extending OPC UA to the field level.

Only OPC UA technology scales from the sensor to the cloud and back, transporting standardized information models via secure communications across plant networks in a way that streamlines the deployment and operation of industrial automation implementations.

The OPC Foundation is the global gravity-center for the next generation of field-level communications: 320 experts from 65 companies define OPC UA FX (Field eXchange) specification extensions for a harmonized process and factory automation solution including Safety, Motion, and Real-time. Users will, in our view, benefit from these important building blocks: (1) the world's largest eco-system for interoperability, with (2) OPC UA as the framework for secure information exchange, with (3) standardized information models and semantics (such as the UA-based Dexpi, VDMA's models, MDIS, and PA-DIM), and now with (4) Ethernet APL connectivity from the Edge into the field devices.

Moreover, the PA industry will be very well served with the inclusion of OPC UA across communications frameworks such as the O-PAS™ and NOA, that will undoubtedly benefit from Ethernet-APL.

The future of process control is available today – Ethernet-APL is that future.



Stefan Hoppe
OPC Foundation
President

Profibus and Profinet International

The widespread use of Ethernet in the field of the process industry is on the verge of a breakthrough thanks to the results of the Ethernet-APL project.

Some may criticize the long development time. But all industrial companies and organizations involved in the project were concerned with creating a viable overall solution. Since PI (PROFIBUS and PROFINET International) has been focusing on process industry applications with its technologies since the 1990s, the results for PROFINET have come at the right time, so that, now that PA Profile 4.0 has been made available, the last building block of PROFINET is also available for process technology applications.

The widespread use of Ethernet-APL will not be long in coming. One of the main reasons for us as PI is that it fulfills one of the main requirements of NAMUR for the realization of NOA. Another lies in the fact that the main organizations for industrial communication systems are developing the standard together with well-known device and system manufacturers who serve the process industry with products. This ensures worldwide coverage by a standard from the very beginning.

The interest of end users in the results is high. This is proven by the test setups in their laboratories based on first prototypes of devices from different industry partners. The results of the tests have been reported positively in public, which pleases us very much. It has been clearly demonstrated that Ethernet-APL is suitable as a physical layer in the field of process automation and as a base technology for higher-level applications.

Experts from PI are significantly involved in the results of the project. The motivation for us to produce a perfect technology together with other organizations in a result-oriented cooperation was and still is very high and we are looking forward to further cooperation.



Karsten Schneider
Profibus and Profinet International
Chairman

Ethernet comes to the field level— 2-wire connection and intrinsically safe power supply with APL

Since the 1980s, Ethernet-based communication has been used in more and more applications, primarily in the office world. In the industrial sector however, the connection of sensors and field devices in the process industry has remained the domain of 4 ... 20 mA technology. The requirement of intrinsic safety (explosion protection) as well as the desire for simple 2-wire connection made the use of Ethernet impossible.

However, the need for high-performance communication is growing, even in hazardous areas. For the increasing vertical integration of measurement devices to the cloud, the classic fieldbuses represent a major hurdle. In order to process information from the field with IT means, protocols and data formats have to be converted manually.

APL provides a technology that allows real IP communication to the field level and into hazardous areas. The requirement for 2-wire connection is fulfilled, as is the intrinsically safe power supply of the field devices via the same lines.

Since different protocols can be run simultaneously over the same medium, the question of „the one protocol“ also loses its significance. OPC UA is already hinting at a solution to this question as well.

ABB is working intensively on the introduction of APL for its measurement portfolio based on its successful TopWorks platform for 2- and 4-wire devices.

Customer benefits

- » Forced separation of IT and OT becomes obsolete, easy vertical integration of field devices greatly simplified
- » Automation benefits from developments in Ethernet and corresponding protocols.
- » Independence of the physical layer from the protocol
- » Integration of complex field devices (WebCam, IR camera...) into the same network



Short Profile

ABB (ABBN: SIX Swiss Ex) is a leading global technology company that energizes the transformation of society and industry to achieve a more productive, sustainable future. By connecting software to its electrification, robotics, automation and motion portfolio, ABB pushes the boundaries of technology to drive performance to new levels. With a history of excellence stretching back more than 130 years, ABB's success is driven by about 105,000 talented employees in over 100 countries.

Talk to the expert

If you would like more information, our Platform Manager Tilo Merlin will be happy to assist you.

tilo.merlin@de.abb.com
Phone: +49 151 4261 8291
abb.com/measurement

Critical Factors for APL Success

Security, ease-of-use and flexibility will drive industry and customer adoption

Digital transformation is driving increased demand for data, and APL will be a transformational step on that journey, promising improvements in data speed and accessibility. By eliminating data silos, information becomes more actionable—by more people—with fewer delays. Operations can become more agile and responsive. Yet, to deliver on this promise, implementation of APL will succeed only when a few critical requirements are met.

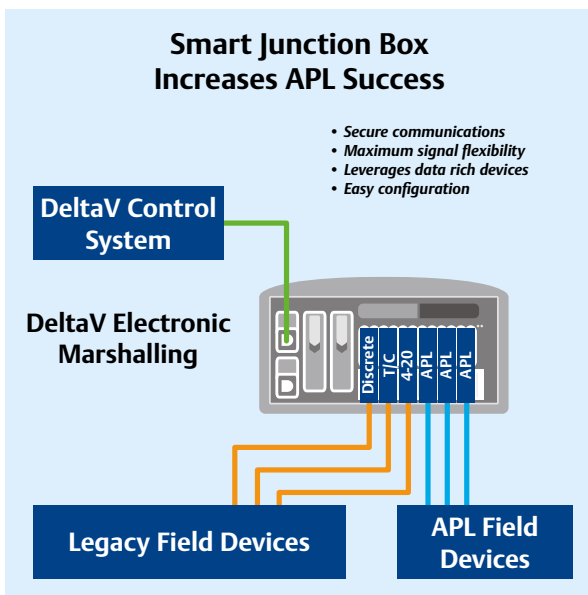

SECURITY: As intelligent devices and expanded communication infrastructure is deployed to the field, security of the network becomes increasingly critical. It is imperative that field device protocols have mandatory standards-based security, natively embedded in the protocol. Leaving security as an optional variable leads to unacceptable risk to the automation system and data integrity.

EASE-OF-USE: User familiarity with tools for device configuration, calibration and troubleshooting will bring the most widespread adoption and faster attainment of value. If specialized training, tools and expertise are required, adoption will be more complicated, thus slower. Adoption will be hindered if OT personnel can't confidently implement APL without requiring substantial IT support.

FLEXIBILITY: A scalable strategy and technology platform is critical. For example, the ability to simplify integration of various signal types with one unified architecture will reduce complexity and allow organizations to scale adoption as they are ready, regardless of signal type (eg. discrete, RTDs, 4-20 mA, etc.) There's an added benefit of data routing efficiency. With APL, the control system is no longer burdened with data from instrumentation dedicated to asset health monitoring or other non-control functions.

Building an APL-ready portfolio

Emerson is committed to making APL adoption secure, easy and flexible, with an advanced portfolio of APL-ready products to future-proof your facility.

To learn more or discuss your APL strategy, contact us at:

APL-Success@Emerson.com

Emerson's Roadmap to APL Success

- » Choose protocol with native and mandatory security
- » Leverage decades of experience with familiar tools and work practices to simplify adoption
- » Prioritize flexibility to integrate various signal types and route data efficiently to those who need it most

Highway for digital data

Although field instruments in process industry have performed their compulsory measurements for years now, a free-style program that supplies information is also a possibility—at least in theory. Analog technology is not suitable, plus the fieldbus technology is overly complex for many users, which is why it has never really established itself.

While Ethernet has become the standard in industrial use in other sectors due to its high speed and seamless integration into IT systems, it was only used in the process industry for controller-controller communication or to connect to the higher levels. Use at the field level in a process plant was out of the question because of the limited cable length (up to 100 m), the unsuitability for use in potentially explosive areas of a plant and the typical cabling with Cat5/6 cable and the RJ-45 plug.

Fit for use in the field

Ethernet-APL is a technology that can bridge distances of up to 1000m. It relies on power supply and data transmission via the same two-wire cable, and simple, reverse polarity protected connection technology. Furthermore, Ethernet-APL is an intrinsically safe solution, similar to today's fieldbus installations. Successful tests of the Ethernet-APL technology have already revealed:

- » Plugs and different topologies enable simple and flexible installation
- » Remote access and fast data transmission simplify and speed up commissioning
- » Ethernet communication via two-wire fieldbus cable is stable and robust
- » Data from smart instruments can be bypassed a process control system via the "second channel" in line with the Namur Open Architecture

More process data and more diagnostics information create transparency and help to optimize the processes. In the future, data from the field can be accessed without interpretation issues. The data are available for use with digital services such as the Netilion ecosystem from Endress+Hauser. In this way, concepts for predictive maintenance controlled with real-time data

from the field devices can be realized. The algorithms are available but have to be processed in the cloud. Ethernet-APL acts as a data highway making the data of all devices available in the field. Endress+Hauser expands the already existing Industrial Ethernet portfolio with Ethernet-APL devices for all relevant measurement principles: Flow, Level, Pressure, Temperature, Analysis. This makes the Ethernet product portfolio also available for the process industries such as chemical or oil and gas.



Talk to the expert

If you have any questions about Ethernet-APL, please contact Benedikt Spielmann, Marketing Manager Industrial Communication at Endress+Hauser.

benedikt.spielmann@endress.com

Phone: +41 61 715 7676

www.endress.com/apl

Process instrumentation for the future

KROHNE combines accurate measurements with modern protocols

KROHNE is a world-leading manufacturer and supplier of solutions in industrial process instrumentation. KROHNE offers supporting products and services for one-stop-shopping and in industries as widespread as oil and gas, water and wastewater, chemical and petrochemical, food and beverage, power, minerals and mining and marine.

We have the right solution for your measurement task—even under harshest conditions. That does not only hold true for the process side, but also for our instruments' communication to state-of-the-art automation and IT systems. We get along well with all relevant logic controllers and distributed control systems on the market, and support the common digital interfaces and protocols. We speak fieldbuses and industrial Ethernet and provide the matching integration software. We believe in Ethernet—today you can already get KROHNE instruments with Ethernet-based interfaces. Ethernet-APL will allow this universal interface to span large distances and to be deployed in hazardous areas. Ethernet-APL brings Ethernet to the field, finally. This will allow the use of the most modern protocols, which are directly understood by IT systems as well. Ethernet is the key to IT/OT convergence and the motor of the Industrial Internet of Things (IIoT).



KROHNE covers all relevant process parameters:

- » Flow
- » Level
- » Pressure
- » Temperature
- » Analytics

Talk to the expert

Christoph Spiegel will be happy to answer your questions related to Ethernet-APL for reliable process instruments.

c.spiegel@krohne.com

Phone: +49 203 301 4499

www.krohne.com

Pepperl+Fuchs— Paths to Digital Transformation

Pepperl+Fuchs, one of the world's leading companies in industrial sensor technology and intrinsically safe explosion protection, has been a pioneer for future technologies in the automation industry for more than 70 years. This is true today more than ever, because with future-proof innovations up to application-oriented cloud connectivity solutions, the Mannheim-based company is paving the way to digital transformation for its customers.

With Sensorik4.0®, Pepperl+Fuchs combines innovative, communication-enabled sensor solutions for Industry 4.0 scenarios. A comprehensive portfolio for industrial communication offers intelligent components that clear the way for the link between IT and OT in factory automation.

Since Industry 4.0 also requires the digital transformation of applications in the process industry, Pepperl+Fuchs collaborates with this international group of well-known manufacturers to make Ethernet available for this market. The Pepperl+Fuchs FieldConnex® Field Switch is the first switch to connect common communication technology with Ethernet-APL. As one further enabler technology for IIoT applications, the Pepperl+Fuchs

brand ecom offers solutions for mobile computing and communication that simplify digitalized applications and processes in process plants. As a result, concepts like remote service and predictive maintenance are just as real as fully networked production systems throughout automation.

Talk to the expert

Andreas Hennecke

Phone: +49 621 776-1601

ahennecke@de.pepperl-fuchs.com

www.pepperl-fuchs.com/apl



Networking Infrastructure with Ethernet-APL Switches

Connecting field devices with controllers and the cloud

As a leading innovator in Industrial Ethernet Switch technology, Phoenix Contact provides trusted solutions for rugged environments. Our in-house design expertise in network switches, intrinsic safety, fieldbus, and Industrial Ethernet protocols makes Ethernet-APL a natural fit for the Phoenix Contact portfolio.

Accordingly, Phoenix Contact has presented the first working prototypes of Ethernet-APL switches in demonstrators at the NAMUR Main Meeting in November 2019 and the ARC Forum in February 2020. This switch provides 200 meters spur length per field device and is well-suited for skid and modular system designs.

Our Ethernet-APL portfolio will ultimately include Power Switches, Field Switches and complement the many process, fieldbus and automation products we already offer as a trusted partner to our customers.

With our Process Industry slogan of an “Enhanced Connectivity for Smart Production” we are aware of the expectations you have of any new technology, and keen to prove that we and the other founding members of the APL Project are your partner in this new generation of Ethernet-based technology.

More info on Ethernet-APL:
phoe.co/Ethernet-APL

Our expertise in process automation:

- » Industrial Ethernet Technology
- » Intrinsic Safety
- » Fieldbus Power Supplies
- » PROFINET, EtherNet/IP and HART-IP
- » OPC-UA
- » NEC/IECEX/ATEX
- » Cyber Security



APL is suited to the Open Architecture activities across the globe, such as those of the NAMUR community.

About Phoenix Contact

Phoenix Contact is a worldwide market leader for components, systems, and solutions in the fields of electrical engineering, electronics, and automation. As a leading supplier to the process industry we are a founding member of the APL Project and develop solutions for Industrie 4.0 as well as the digitalization of all industries.

Talk to the expert

Jason Norris
Group Leader, Process Automation
Automation Infrastructure
Cell: (+1)-713-210 9460
jnorris@phoenixcontact.com

Proven DCS solutions to enable the Connected Enterprise

Characterized performance

Defined system architectures, enabled by PlantPAX® system sizing tools, allow you to design the DCS for your needs with minimal risk and proven system performance.

Scalable and flexible

Built to scale according to your needs using the same platform for a single standalone equipment to a large, distributed architecture.

High availability

Provides high availability with redundancy built-in at all levels and supported technologies from the I/O to controllers, networks, and servers.

Maximize efficiencies

Controllers purpose-built for process reduce architecture complexity. A small footprint reduces lifecycle maintenance. Integration of networked drives and field devices allows for easier information retrieval.

Future-ready

Leveraging the standard Advanced Physical Layer for Ethernet (Ethernet-APL) to extend EtherNet/IP to all areas of process operations, providing uniform support for concepts such as the NAMUR Open Architecture (NOA) and Industry 4.0.

Learn more at:

www.rockwellautomation.com

Plant-wide control
and optimization

Scalable and modular

Secured open and
information-enabled

Flexible delivery
and support

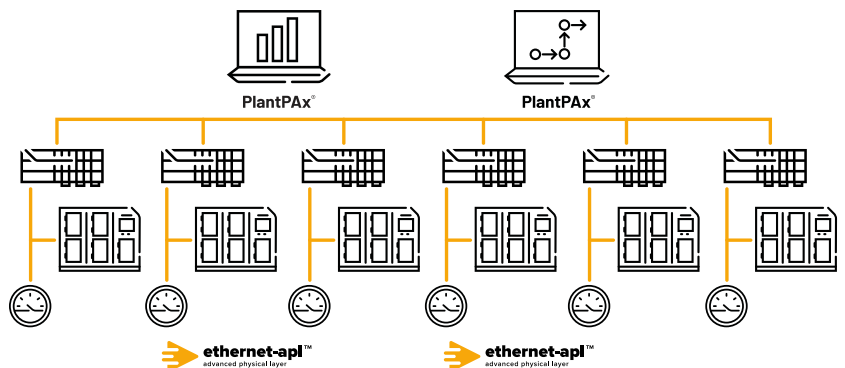



Digital Transformation in Control Valves

Ethernet-APL Enables Fast Data Transmission from Positioners

SAMSON is a provider of products and solutions to control all types of process media. In this role, SAMSON has been involved in the Ethernet-APL project as an industry partner right from the get-go. And SAMSON is convinced that Ethernet communication will drive transformation in the process industry.



SAMSON presented its first APL demonstrator as early as in 2016. The trial setup served as the basis for further research and development in the company's own DIGITAL LAB. Today, digital positioners with integrated diagnostic functions, including a SAMSON-developed Ethernet-APL connection using an APL switch, are integrated into the communication. The use of IP-based protocols, such as PROFINET™ and EtherNet/IP™, ensures a quick exchange of data with the positioner. Device handling is optimized as operating instructions, certificates and integration files are more readily accessible. At the same time, access to the smart features of the control valves, as implemented in the diagnostic data collected and analyzed in the positioner, ensures efficient start-up, configuration and diagnostics. Communication is established over a 10BASE-T1L two-wire line following the new 10 Mbit/s Ethernet standard, which makes it suitable for use in hazardous areas as well.

Want to find out more?

You can get further information on the design of Ethernet-APL and our innovative products for IIoT environments at:

Melanie.Duerr@samsongroup.com

Phone: +49 69 4009-2071

www.samsongroup.com

Upcoming product: TROVIS 3797 Positioner

- » Suitable for Ethernet-APL connections
- » Communication using PROFINET™ profile 4.0
- » Integrated valve diagnostics
- » User-friendly access to device data
- » Interchangeable option modules
- » Easy replacement of devices supported by profile device master data (GSD) file
- » Connection to higher-level asset management systems (such as SAM VALVE MANAGEMENT) using OPC UA

Digitalization in process instruments

Fully exploit the potential of your data—
from the field to the cloud with SITRANS IQ.

What if production plants could talk? The data through which they communicate tells us a lot about their condition. Use connectivity to analyze this data in order to optimize processes. SITRANS IQ—Measuring what matters.

In addition to process parameters, a plant generates a constantly high volume of status data: friction coefficients every time a valve moves, tiny changes in echo signal strength, constantly rising temperatures in the electronics, or changes in other parameters. What's new is that this status data can now be extracted from the plant, stored, analyzed, and prepared to meet the specific needs of the operator and continuously lower marginal costs. From targeted monitoring of critical measurement points to complete asset management covering instrumentation for multiple plants, the opportunities are unlimited.

What's required is a structure with suitable connectivity solutions to link the field level with a higher control level, the cloud, or an on-premise solution. That's why we devised SITRANS IQ.

The continuous evolution of SITRANS IQ includes ever advancing technology standards such as Ethernet-APL which play an important role in enabling seamless access to your critical data. This last layer of accessibility to the field devices will unleash advancements in predictive maintenance, diagnostic capabilities, and real-time information of the plant.

Combining flexible communication options with a powerful suite of SITRANS IQ applications and a complete range of intelligent SITRANS field devices, Siemens continues to bring the solutions that enable increased plant transparency and the advanced use of data from the field.

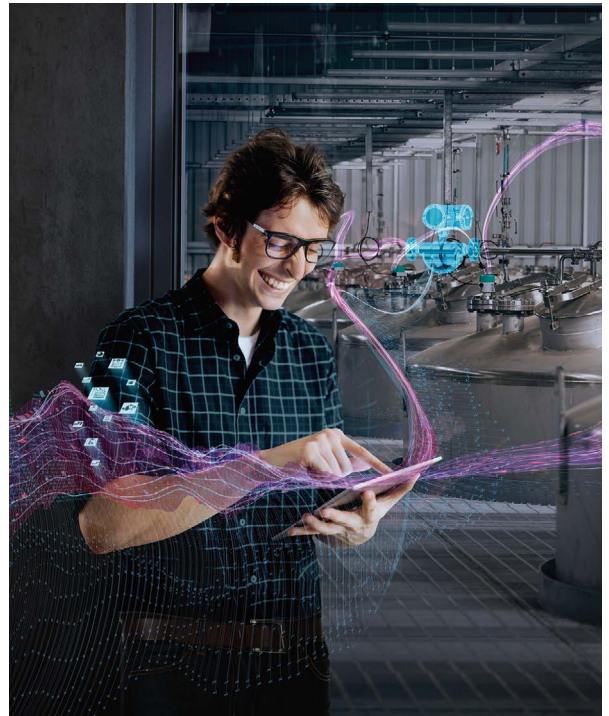

Think digitally and learn more

Learn more about digitalizing your process plant—and how you can benefit from comprehensive field level integration today.

jan.kiehne@siemens.com

www.siemens.com/pi/digitalization

Ethernet-APL— (R)evolution of data transmission

The new benchmark for digitalization in the process industry. For R. STAHL, Ethernet-APL is another milestone in its long history of digital innovations for hazardous areas. The new Ethernet-APL field switches and power switches combine high quality explosion protection for Zone 1 with user-friendly functionality.

Since entering digital data communication for hazardous areas with the first intrinsically safe remote I/O in 1987, R. STAHL has been actively involved in developments and standardization. In 2009 the first Zone 1 remote I/O with Ethernet connectivity via fiber optic cables was presented and today R. STAHL is actively working in the Ethernet-APL Working Group on the 2-wire Ethernet. At the same time, R. STAHL is also involved in the IEC in the creation of the new standard for intrinsic safety for 2-wire Ethernet. This is published in IEC TS 60079-47 under the title 2-WISE (2-Wire Intrinsically Safe Ethernet). Based on these activities, new infrastructure components for Ethernet-APL are in development. The field switches for installation in Zone 1 are powered via the Ethernet-APL trunk and can operate and supply up to 16 field devices with "2-WISE" intrinsic safety. About 90 watts of power are available via the trunk using power switches, which are also responsible for converting the

"classic" 4-wire Ethernet into the new 2-wire physical layer. The Zone 2 versions of the Field Switches are also available with a direct connection to 4-wire Ethernet 100BASE-TX, but with a separate supply. In addition, all Field Switches offer extensive functions to carry out both logical and physical layer-specific diagnostics and thus to simplify commissioning and troubleshooting. In addition to the new Ethernet-APL infrastructure components for Zone 1 and 2, R. STAHL also offers the installation technology. With the extensive range of field housings and installation material combined with over 30 years of experience in the system business, we bring digitalization to all hazardous areas.

Highlights of the Ethernet-APL infrastructure:

- » Installation according to ATEX and IECEx in Zone 1 and 2
- » Ethernet-APL field switches with 16 Ex i spurs
- » Supply and communication via the trunk or connected to 100BASE-TX
- » Support of 2-WISE according to IEC TS 60079-47
- » Ethernet-APL power switch with approx. 90 W
- » Integrated diagnostics for communication and physical layer

Your contact in the Ethernet-APL project

Dipl. Ing. (BA) André Fritsch, Senior Product Manager Remote I/O and Fieldbus

andre.fritsch@r-stahl.com
r-stahl.com/en/apl

Short Profile

R. STAHL was founded as a German family owned company in 1876 and has been active in explosion protection since the 1940s. AUTOMATION has been established in the company for 50 years and has done pioneering work, for example, with explosion-proof remote I/O systems and intrinsically safe fieldbus solutions. We are actively involved in future topics such as NAMUR Open Architecture (NOA) or the Open Process Automation Forum (OPAF) in order to enable our customers to digitalize their process plants. Today R. STAHL is one of the world's three largest suppliers of components and solutions for electrical explosion protection. With system solutions for even the most extreme environmental conditions, we are number one. R. STAHL is actively involved in standardization according to ATEX, IECEx or NEC/CEC for its customers in order to guarantee a high national and international safety standard. From development through production to operation in the field, we act in accordance with the "Made in Germany" seal.

Networking the field

Ethernet-APL: VEGA level and pressure sensors for Industry 4.0

Since VEGA customers also prefer simple concepts and greater flexibility for their instrument networking, the technology leader in radar measurement is working alongside other companies to develop a universal standard. With its new generation of level and pressure sensors, VEGA is bringing Ethernet-APL into the world of industrial processing systems.

VEGA: Efficiency starts with the sensor

When it comes to implementing Ethernet-APL as the new standard in process automation, VEGA is at the forefront: The Schiltach-based manufacturer of level and pressure measurement technology is developing an IIoT sensor generation based on established protocols that offers future-oriented solutions for the process industry.



Trends such as batch size 1, individualisation and expanded networking are making Industry 4.0 concepts more and more attractive in the process industry. One thing is certain: Simple and secure “reach-through” from the system level to the field level with established Ethernet protocols brings real added value for users.

In addition to ensuring practical cable lengths, reliable sensor supply and explosion protection, the goal is, above all, to expand interoperability. Thanks to Ethernet-APL, measurement data and device information can now be communicated consistently across all hierarchical levels: with no barriers, from Ex areas to the cloud.

“Ethernet-APL fits so well to VEGA because its objective is flexibility and simplicity,” explains Holger Sack, head of VEGA product management. The future standard makes it easy to tie sensor data into the IIoT and the cloud.

Talk to the expert

In-depth process know-how and service are VEGA's key strengths. We're happy to answer your questions and provide support, so that your processes are equipped for the digital future:

info.de@vega.com

Phone: +49 7836 50-0

www.vega.com

Available as of mid-2022

- » VEGA sensors for level and pressure with Ethernet-APL
- » Digital instrument networking with reliable Ex protection
- » Ethernet-based communication right down to the individual sensor in the field
- » Easy connection to the IIoT and the cloud

OpreX™ + ethernet-apl™

Looking for ways to future proof your plant and set your operation on the path to sustained growth and profitability? Yokogawa's lineup of OpreX solutions and the new Ethernet-APL technology promise to do just that by enabling the digitalization and seamless integration of operations at every layer of your organization, from the C-suite to the plant floor, while bringing you the benefits of increased range, the faster sharing of data, and greater safety, even in the most hazardous environments.



Ethernet-APL was developed in concert with the world's leading industry standard development organizations and many of the most well-known names in the process automation industry, and Yokogawa has been involved in this pioneering effort from the beginning. Based on IEEE and IEC standards, Ethernet-APL is a protocol-neutral physical layer that will bring the Ethernet down to the field level and make digitalization for the process industries a reality by enabling Ethernet-based communications between enterprise systems and field instrumentation. Relying on the rugged physical connections afforded by conventional 2-wire cabling, it presents a real and viable solution to the need for long-reach connectivity, the rapid exchange of valuable data and, above all, safe operation in hazardous environments, while eliminating the need for gateways, proxies, and other conventional workarounds for connecting devices to upper-level systems.

Under the OpreX brand, Yokogawa offers a comprehensive portfolio of industrial automation and control products, services, and other solutions that can create

synergy and add value at every layer and level of your organization, and over all phases of your plant lifecycle. By being directly involved in the development of this intrinsically safe and fast Ethernet-APL technology and offering it as part of the OpreX solutions portfolio, our aim is to prepare you for the future by freeing your plant operations from geographical and temporal constraints, and to set your business on the path to sustained growth and profitability.

Get ready for the future now with OpreX and Ethernet-APL.

Talk to an Expert

Taro Endo
Field Device Expert, Member of Ethernet-APL WGs.
Tarou.Endou@yokogawa.com
www.yokogawa.com

FieldComm Group

www.fieldcommgroup.org/apl

ODVA

www.odva.org/apl

OPC Foundation

www.opcfoundation.org/apl

Profibus and Profinet International (PI)

www.profibus.com/apl



Visit us at Achema Pulse
www.ethernet-apl.org

